

**Ingresso UNI**  
 UNI input

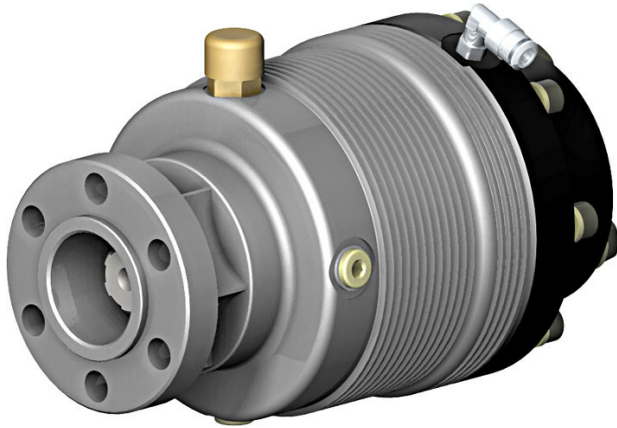

**Uscita UNI**  
 UNI output

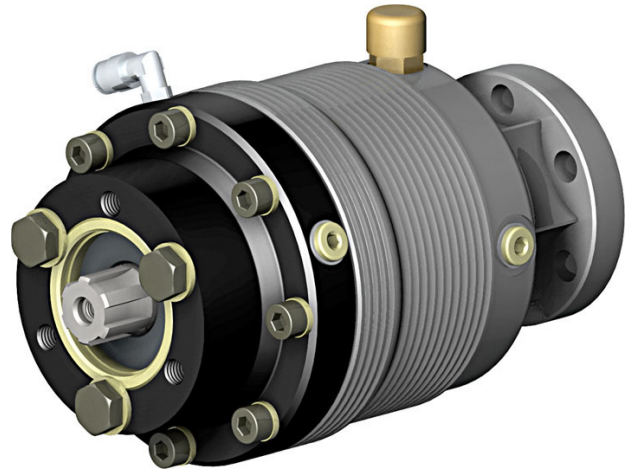

**Ingombro / Dimension**

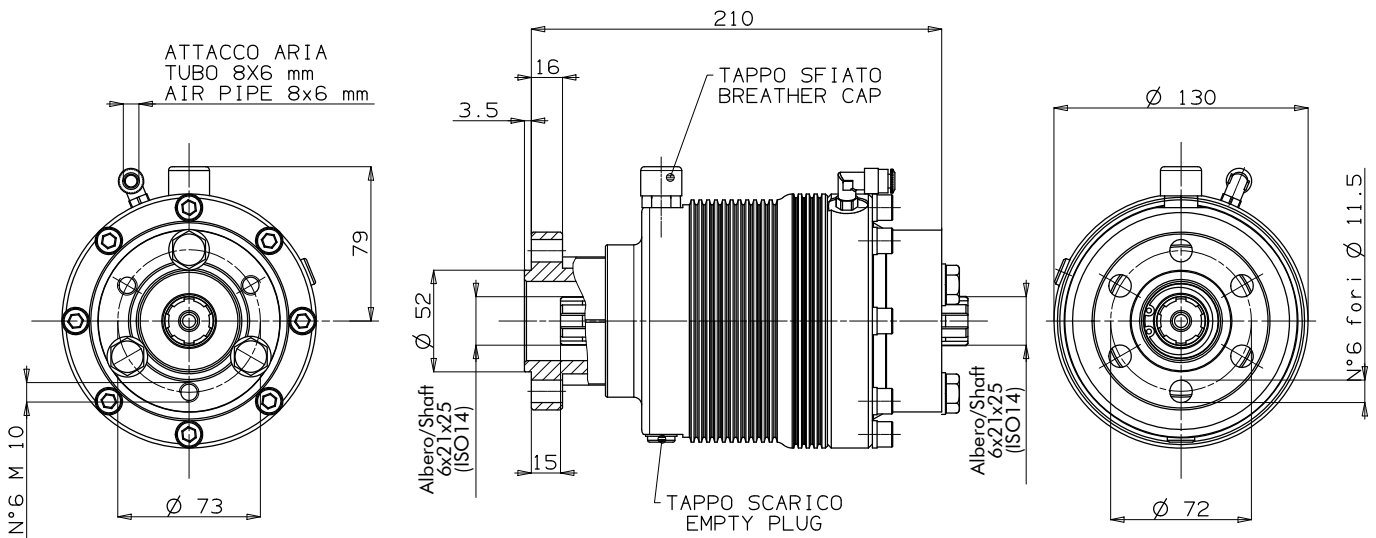

**Dati tecnici / Technical features**

Codice di ordinazione Order code	Versione ingresso Input version	Versione uscita Output version	Coppia nominale Nominal torque	Velocità max. continua Max. continuous speed		Velocità max. intermittente Max. intermittent speed		Peso Weight
			Nm	A vuoto Unloaded	Sotto carico Loaded	A vuoto Unloaded	Sotto carico Loaded	
10301200016	21 UNI	13	250	2600	1500	3200	2000	9,8 Kg