

Oil tanks manufactured using the latest technologies in order to ensure the longest reliability in time. Their dimensions are suitable for the installation behind the vehicle's cabin. They are available in different sizes and capacities, complete with mounting brackets and rubber protections, breather and filler cap (replaceable air filter), oil level gauge and flange for filter predisposition. High versatility is granted by a wide choice of accessories available. **The blank flange is provided included in the standard equipment.**

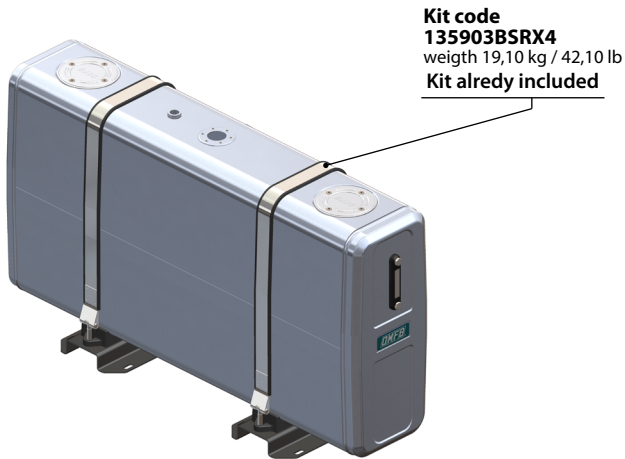

ALUMINIUM						
Filling capacity		Tank code	Suction ports 2x	Filter flange	Weight	
lt	gal				kg	lb
200	53	VUARBS12520	2" NPT	F4 (115mm)	41	90,4

COATED STEEL (RAL 7021) double powder coating (primer + final layer)						
Filling capacity		Tank code	Suction ports 2x	Filter flange	Weight	
lt	gal				kg	lb
200	53	VUGRBS12520	2" NPT	F4 (115mm)	54,3	119,7

Filler cap to be ordered separately, choosing between plastic or metallic version.

Tank dimensions

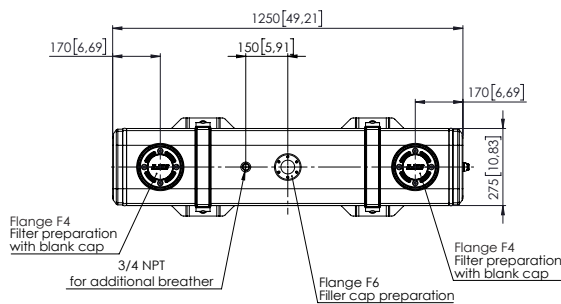

		Oil level min. capacity		Oil level max. capacity	
lt	gal	lt	gal	lt	gal
200	53	143	37,78	170	44,91

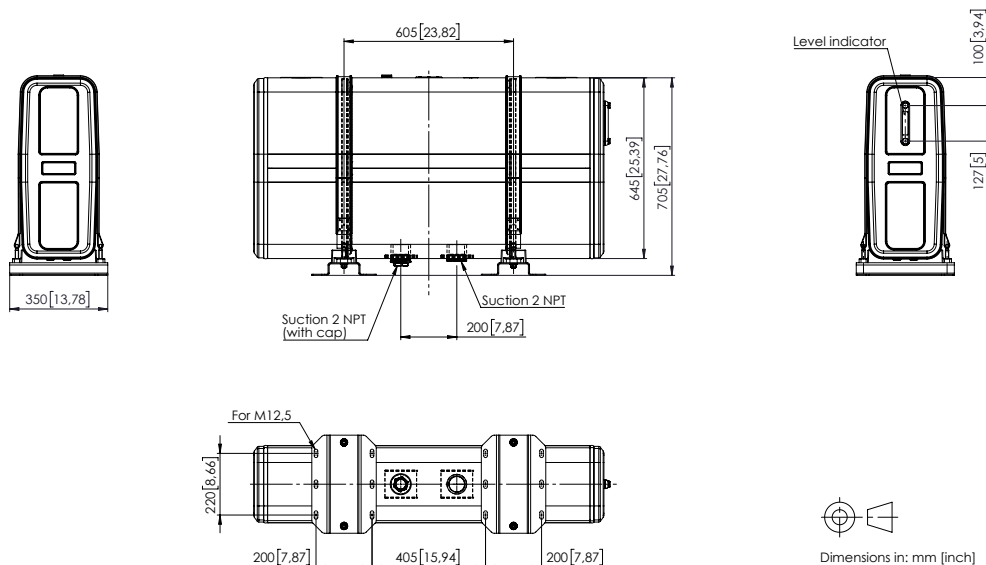

Oil tanks manufactured using the latest technologies in order to ensure the longest reliability in time. Their dimensions are suitable for the installation behind the vehicle's cabin. They are available in different sizes and capacities, complete with mounting brackets and rubber protections, breather and filler cap (replaceable air filter), oil level gauge and flange for filter predisposition. High versatility is granted by a wide choice of accessories available. **The blank flange is provided included in the standard equipment.**

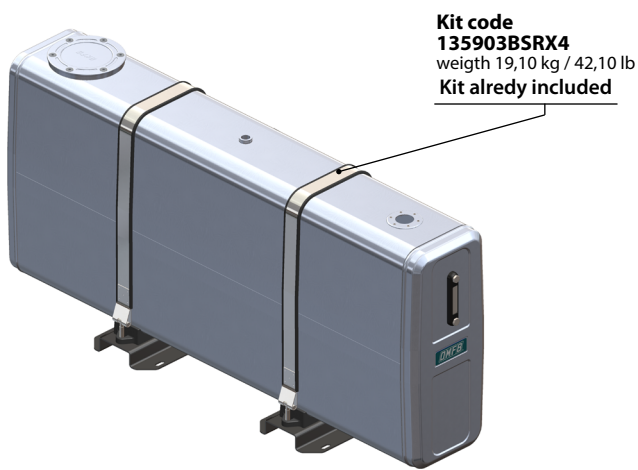

ALUMINIUM						
Filling capacity		Tank code	Suction ports 2x	Filter flange	Weight	
lt	gal				kg	lb
250	66	VUARBS15020	2" NPT	F2 (175mm)	44	97

COATED STEEL (RAL 7021) double powder coating (primer + final layer)						
Filling capacity		Tank code	Suction ports 2x	Filter flange	Weight	
lt	gal				kg	lb
250	66	VUGRBS15020	2" NPT	F2 (175mm)	60,1	132,5

Filler cap to be ordered separately, choosing between plastic or metallic version.

Tank dimensions

